



VESUVIO PLUS

F1000 C - CV

GASPARIN
impianti



Caratteristiche Tecniche VESUVIO PLUS F1000 C

Technical specifications - Technische Daten - Caracteristiques Techniques

Frantoio a mascelle Jaw crusher Backenbrecher Concasseurs à mâchoire	Type: F 1000 1.000 x 650 mm 30* ÷ 180 mm		
Tramoggia di carico Feed hopper Aufgabebunker Trémie alimentation	Dim. 2.000 mm x 3.760 mm 4,5 m³		
Alimentatore vibrante a barrotti Bars vibrating grid Stangenvibrationsaufgeber Scalpeur vibrant	Dim. 970 mm x 3.300 mm Barrotti-Bars-Stangen-Doigts std. 40-55 mm		
Motorizzazione Power unit - Motor - Moteur	168 Kw / 225 Hp		
Nastro trasportatore principale Main belt conveyor Hauptförderband Transporteur principal	Type: 0.8 x 10 Dim. 800 mm x 10.000 mm		
Cingoli Track drive - Raupenfahrwerk Chenilles	450 mm x 3.480 mm		
Produzione massima Max production Produktgröße - Capacité	240 Ton / h		
Peso totale Total weight Gewicht Poids	33.000 Kg.		
Dimensioni di trasporto Transport dimensions Transportabmessungen Dimensions de transport	12.670 x 3.100 x 2.550 mm <i>con/with/mit/avec tn std.</i> 12.600 x 3.100 x 2.550 mm <i>con/with/mit/avec tn 0.8x12 opz.</i>		
F 1000 C - CV Impianto abbattimento polveri Dust suppression system Staubabsaugung Abattage de poussière	F 1000 C - CV Pompa travaso gasolio Diesel tank filling pump Dieselolbehälterfüllpumpe Pompe de remplissage réservoir de gasoil		

Caratteristiche Tecniche VESUVIO PLUS F1000 CV

Technical specifications - Technische Daten - Caracteristiques Techniques

Frantoio a mascelle Jaw crusher Backenbrecher Concasseurs à mâchoire	Type: F 1000 1.000 x 650 mm 30* ÷ 180 mm		
Tramoggia di carico Feed hopper Aufgabebunker Trémie alimentation	Dim. 2.000 mm x 3.760 mm 4,5 m³		
Alimentatore vibrante cieco Flat vibrating feeder Flach Vibrationsaufgeber Alimentateur vibrant plan	Dim. 970 mm x 1.900 mm		
Vaglio vibrante a 2 piani vaglianti Double deck vibrating screen Zwei Decken Vibrationssieb Crible vibrant à deux plateformes	Dim. 1.020 x 1.800 mm Lam. forata fori rombo-Diamond hole pouched plate-Diamantgebohrte Platte- Plaque percée losange - 60mm std.		
Motorizzazione Power unit - Motor - Moteur	168 Kw / 225 Hp		
Nastro trasportatore principale Main belt conveyor Hauptförderband Transporteur principal	Type: 0.8 x 10 Dim. 800 mm x 10.000 mm		
Cingoli Track drive - Raupenfahrwerk Chenilles	450 mm x 3480 mm		
Produzione massima Max production Produktgröße - Capacité	280 Ton / h		
Peso totale Total weight Gewicht Poids	34.000 Kg.		
Dimensioni di trasporto Transport dimensions Transportabmessungen Dimensions de transport	12.670 x 3.100 x 2.550 mm <i>con/with/mit/avec tn std.</i> 12.600 x 3.100 x 2.550 mm <i>con/with/mit/avec tn 0.8x12 opz.</i>		
F 1000 C - CV Impianto abbattimento polveri Dust suppression system Staubabsaugung Abattage de poussière	F 1000 C - CV Pompa travaso gasolio Diesel tank filling pump Dieselolbehälterfüllpumpe Pompe de remplissage réservoir de gasoil		

* La regolazione min. consentita è in funzione della durezza del materiale e del rapporto di riduzione.

* The minimum operating gap varies in function of the material hardness and of the in/out granulometry ratio.

* Die minimale Einstellung hängt von der Härte von Baustoffen und vom dimensional Beziehung des Produktes beim Eingang und beim Verlassen des Brechers ab.

* Le réglage minimum dépend par la dureté des matériaux et par le rapport dimensionnel du produit à l'entrée et à la sortie du concasseur.

Optionals F1000 C / CV

- **Separatore magnetico** - Band magnetic separator - Magnetabscheider - Séparateur magnétique
- **Radiocomando Liv. 1/Liv.2** - Remote control - Fernsteuerung - Commande à distance
- **Nastro laterale** - Secondary belt conveyor - Seitenaustragsförderer - Bande transporteuse latérale
- **Pompa per impianto abbattimento polveri** - Self priming water pump for dust suppression - Selbstanlassende Pumpe für staubabsaugung - Pompe pour installation d'abattage de poussière

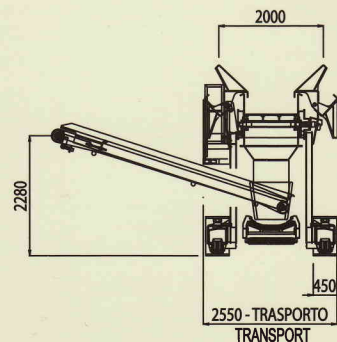
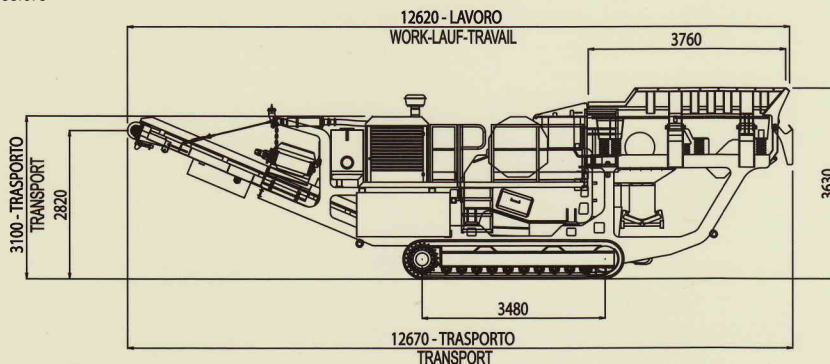

Gasparin Impianti s.r.l. - Via Giorgione, 17 - S.S. Feltrina - 31040 Musano di Trevignano - Treviso - Italy
Tel. +39 0423 670201 - Fax +39 0423 676575 - www.gasparinimpianti.com - E-mail: info@gasparinimpianti.com